

2", 3" & 4"



CLEVIS HANGER

Light Duty Model 4200

SIZE:

Light Duty: 1/2" thru 4"

FINISH:

Electro-Galvanized

FUNCTION:

Allows vertical adjustment of pipe after installation

FEATURES:

- Maximum temperature Plain 650° F, Galvanized 450° F
- Conforms with Federal Specification WW-H-171 (Type 1), Manufacturers Standardization Society (MSS) SP-69 (Type 1)
- When using an oversize clevis, it is recommended to install a full-width spacer on the cross bolt to prevent failure due to disfiguring the U-strap
- When using insulated pipe, order hanger sized to correspond to overall dimension. It is also recommended to use insulation shields

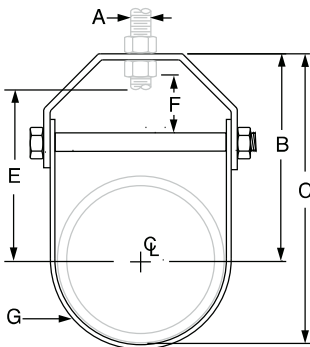

Light Duty Clevis Hanger: Loads (LBS) • Weights (LBS) • Dimensions (IN)

ITEM CODE 4200	ITEM CODE 4300	SIZE	MAX LOAD	WEIGHT	A ROD SIZE	B	C	E ROD TAKE OUT	F ADJUSTMENT	G WIDTH LOWER
4200-0050EG	4300-0050P	1/2	200	0.17	3/8	1 5/8	2 1/8	1 1/2	5/8	1/4
4200-0075EG	4300-0075P	3/4	200	0.22	3/8	1 3/4	2 3/8	1 5/16	5/8	1/4
4200-0100EG	4300-0100P	1	300	0.22	3/8	2 1/16	2 3/4	1 5/8	5/8	1/4
4200-0125EG	4300-0125P	1 1/4	300	0.29	3/8	2 3/8	3 5/16	1 11/16	5/8	1/4
4200-0150EG	4300-0150P	1 1/2	300	0.30	3/8	2 15/16	3 15/16	2 1/8	7/8	1/4
4200-0200EG	4300-0200P	2	300	0.34	3/8	3 1/4	4 1/2	2 5/8	1 1/8	1/4
4200-0250EG	4300-0250P	2 1/2	400	0.68	1/2	3 3/4	5 1/4	3 3/16	1 5/16	3/8
4200-0300EG	4300-0300P	3	400	0.72	1/2	4 1/8	6	4 1/16	1 5/8	3/8
4200-0350EG	4300-0350P	3 1/2	450	0.80	1/2	4 7/16	6 1/2	4 3/16	1 13/16	3/8
4200-0400EG	4300-0400P	4	550	0.97	5/8	5 3/8	7 3/4	4 1/2	1 11/16	3/8