



SPLIT RING HANGER

Hinged Model 5100

SIZE:

Range: 1/2" thru 4"

FINISH:

Electro-Galvanized

MATERIAL:

Malleable Iron

FEATURES:

- Bolt and rivet are carbon steel.
- Hinged design provides for economical installation.
- Designed to provide a tight fit on standard steel pipe.
- Conforms with Federal Specification WW-H-171 (Type 25), Manufacturers Standardization Society (MSS) SP-58 and SP-69 (Type 12)

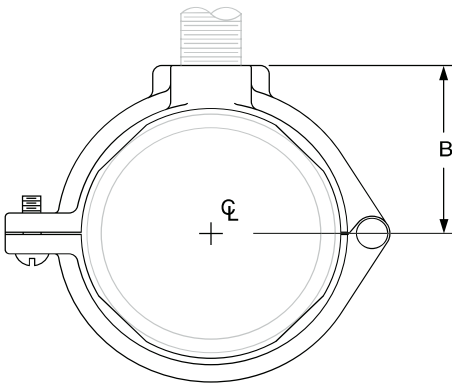

Hinged Split Ring: Loads (LBS) • Weights (LBS) • Dimensions (IN)

ITEM CODE 5000	ITEM CODE 5100	TUBE SIZE	ROD SIZE	MAX LOAD	WEIGHT	B
5000-0050P	5100-0050EG	1/2	3/8-16	300	0.13	7/8
5000-0075P	5100-0075EG	3/4	3/8-16	300	0.15	1 1/16
5000-0100P	5100-0100EG	1	3/8-16	300	0.17	1 1/8
5000-0125P	5100-0125EG	1 1/4	3/8-16	300	0.28	1 1/4
5000-0150P	5100-0150EG	1 1/2	3/8-16	300	0.29	1 7/16
5000-0200P	5100-0200EG	2	3/8-16	300	0.32	1 5/8
5000-0250P	5100-0250EG	2 1/2	1/2-13	600	0.39	2 1/8
5000-0300P	5100-0300EG	3	1/2-13	600	0.48	2 7/16
5000-0400P	5100-0400EG	4	1/2-13	600	1.06	2 7/8