

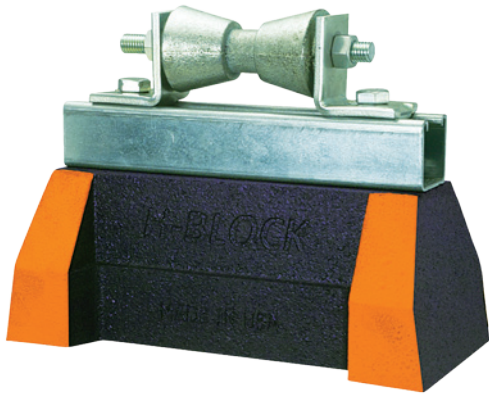

# HBS-R ROLLER SERIES



The HBS-R Series are designed for superior support of gas and refrigeration pipes. The roller allows for longitudinal movements of the pipe. This support is suitable for most types of roofing material or other flat surfaces.

Roof supports come pre-assembled

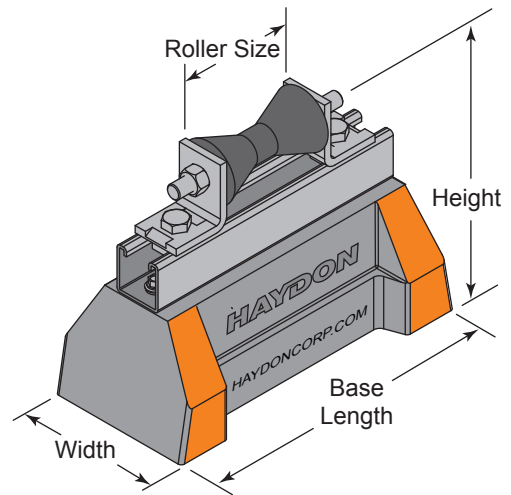

## Specifications – HBS-R Series

**H-Block Support with:**  
1<sup>5</sup>/<sub>8</sub>" H-132 Channel

**MATERIAL** - 100% recycled rubber,  
UV resistant

**PIPE O.D.** - 1" thru 10"

## HBS-R-Roller-Series With 1-<sup>5</sup>/<sub>8</sub>" H-132 Pre-Galv. Steel Channel With Rollers

Model No.	Pipe Size (O.D.)	Overall Height	Height to Roller Center	Strut Length	Width	Base Length	No. of Bases	Weight (Lbs)	Uniform Load Capacity (Lbs) *
HBS-R10-1-2-H-132-PG	1" to 2" (25 to 51mm)	8" (203mm)	7" (178mm)	9.312" (237mm)	5" (127mm)	10- <sup>7</sup> / <sub>8</sub> " (276mm)	1	9.13	2,500 *
HBS-R10-2-3 <sup>1</sup> / <sub>2</sub> -H-132-PG	2" to 3- <sup>1</sup> / <sub>2</sub> " (51 to 89mm)						1	8.94	2,500 *
HBS-R10-4-6-H-132-PG	4" to 6" (102 to 152mm)						1	9.37	2,500 *
HBS-R24-8-10-H-132-PG	8" to 10" (203 to 1254mm)	10- <sup>5</sup> / <sub>16</sub> " (262mm)	8- <sup>5</sup> / <sub>8</sub> " (219mm)			24" (610mm)	2	21.26	2,500 *

\* This load is only for the capacity of the components in this assembly.  
Please consult roofing manufacturer or engineer for roof load capacity