

CONCRETE INSERTS & ACCESSORIES

H-142-IN

Concrete Insert

CHANNEL: $1\frac{3}{8}$ " x $1\frac{5}{8}$ " x 12 Gauge
 Stocked in Pre-Galvanized & Plain
 in 10' & 20' lengths.

*other lengths available

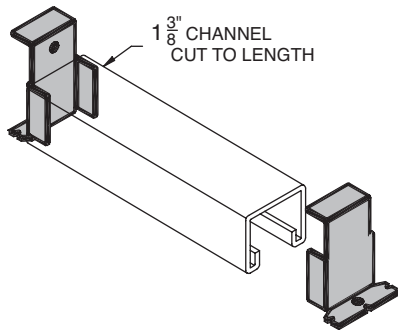

Features

- Loading data was calculated in a concrete mixture which was proportioned so that the compression strength of the concrete was 2,500 to 3,000 pounds per square inch and that the load is dependent on the surrounding concrete.
- Tests were performed with a safety factor of 3, and in accordance with the MFMA Specifications.
- H-STRUT concrete inserts are supplied with either the 1000 or 1001 series end cap and either a styrofoam filler or plastic strip (C-900P) installed in the insert channel to prevent any concrete seepage.
- Stocked in either plain and pre-galvanized, see technical data section for ASTM specifications.
- Inserts should be secured to forms at 16" intervals.
- When ordering, please indicate finish and either foam filler, or plastic closure.

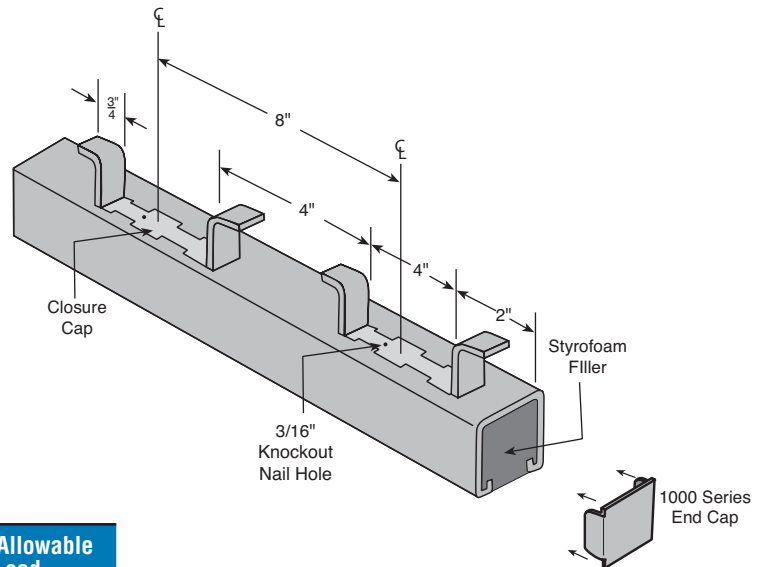

Catalog No.	Length in Inches	Wt./100 Pcs.	Max. Allowable Load
H-142-IN	3	87	500 Lbs.
H-142-IN	4	103	800 Lbs.
H-142-IN	6	134	1000 Lbs.
H-142-IN	8	206	1200 Lbs.
H-142-IN	12	188	No More Than 1800 Lbs. Per 12" Section
H-142-IN	18	282	
H-142-IN	24	376	
H-142-IN	30	470	
H-142-IN	36	564	
H-142-IN	48	752	
H-142-IN	60	940	
H-142-IN	72	1128	
H-142-IN	84	1316	
H-142-IN	96	1504	
H-142-IN	108	1692	
H-142-IN	120	1880	
H-142-IN	240	3760	

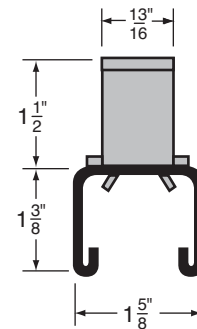

CONCRETE INSERTS & ACCESSORIES

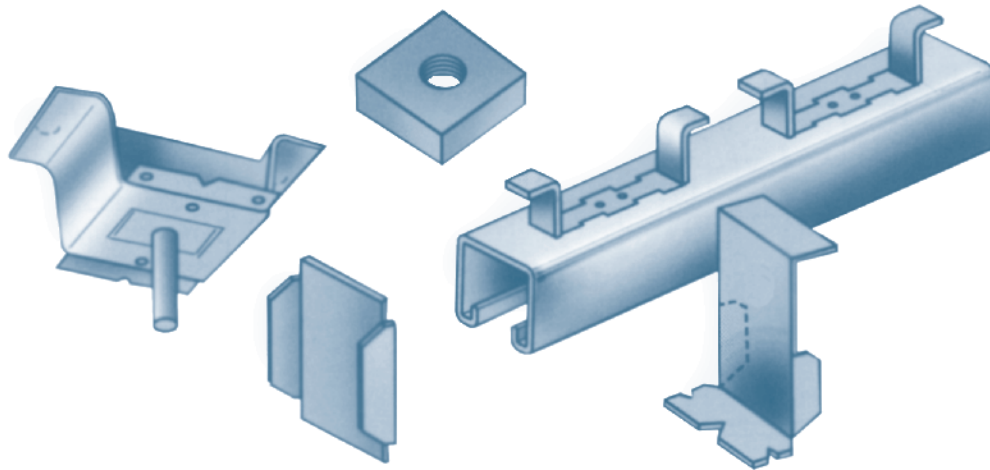

SPECIFICATIONS

GENERAL

H-STRUT Concrete Inserts are designed for the attachment or suspension of framing, piping or equipment to concrete structures where a continuous insert slot is required.

Continuous Concrete Inserts are nailed to the forms through the knockout holes provided in the closure cap (see illustration on next page). Nails may be cut off after removal of the forms.

MATERIAL

H-STRUT Concrete Inserts and Accessories are produced from prime steel covering the following specifications:

- Hot Rolled Carbon Steel ASTM A-1011-04-SS
- Cold Rolled Carbon Steel. ASTM A-366
- Stainless Steel - Type 304/316 ASTM A-240

FINISH

H-STRUT Concrete Inserts and Accessories are stocked in the following finishes:

- Pre-Galvanized. ASTM A-653-G90
- Hot Dipped Galvanized ASTM A-123
- Electro Galvanized ASTM B-633 BSC

LENGTH

H-STRUT Concrete Inserts are produced and stocked in 10 and 20 foot lengths. Other lengths are available upon request.

ORDERING

Specify catalog number, length or size where required and finish when necessary.