

K-PRESS

FORGED BRASS BALL VALVE

PRESS FIT

Two Piece Body • Full Port • Chrome Plated Ball
 Blowout Proof Stem • PTFE Seats • Adjustable Stem Packing
 NSF • FM

Code #101 XL

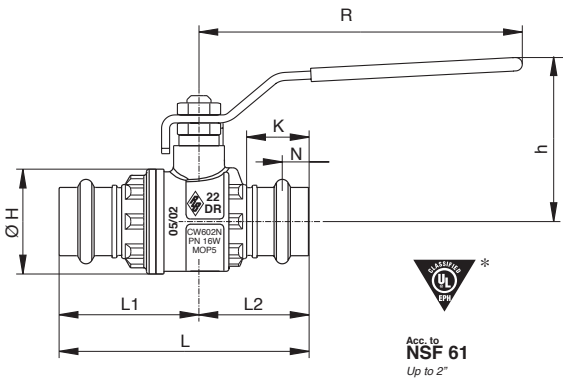
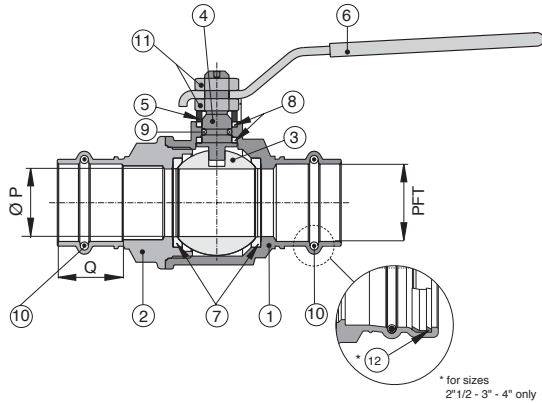

Full port ball valve with PRESS connections from 1/2" - 4", steel handle, yellow grip.

- 600 WOG body rating with 200 CWP press fit rating.
- Temperature to 210° F.
- Blow out proof stem, chrome plated brass ball.
- PTFE seats, seals, and thrust washer.
- Recommended for service in the full open or full closed position.
- Adjustable stem packing.
- 100% tested in the open and closed position at 80 psi.

N Pos	PART NAME	MATERIAL	N PCS
1	BODY	BRASS CW 602N	1
2	END CONNECTION	BRASS CW 602N	1
3	BALL	BRASS CW 617N	1
4	STEM	BRASS CW 614N	1
5	PACKING GLAND	BRASS CW 614N	1
6	HANDLE	STEEL	1
7	BALL SEAT	PTFE	2
8	STEM SEAL/THRUST WASHER	PTFE	2
9	O-RING	NBR	1
10	O-RING	EPDM	2
11	NUT	STEEL CL 04	2
*12	CIRCLIP	STEEL S235JR	1

PFT	ØP	Q	K	N	ØH	L	L1	L2	h	R	Cv	psi MAX WORK PRESS	psi MAX TEST PRESS	Lbs
½"	0.59	0.71	0.67	0.31	1.30	3.13	1.71	1.42	1.89	3.86	18.84	200	600	0.49
¾"	0.79	0.91	0.83	0.39	1.54	3.66	2.05	1.61	2.28	4.80	34.10	200	600	0.82
1"	0.98	0.94	0.83	0.39	1.93	4.13	2.32	1.81	2.44	4.80	49.71	200	600	1.25
1¼"	1.26	1.02	0.83	0.39	2.32	4.41	2.44	1.97	3.07	6.02	102.88	200	600	1.98
1½"	1.57	1.42	1.02	0.49	2.87	5.63	2.91	2.72	3.35	6.02	265.88	200	600	3.40
2"	1.95	1.57	1.20	0.59	3.39	6.52	3.41	3.11	3.80	6.38	306.34	200	600	4.50
2½"	2.40	2.17	1.54	1.08	4.37	8.33	4.43	3.90	5.08	8.07	624.24	200	600	10.87
3"	2.87	2.17	1.54	1.08	5.35	9.07	4.82	4.25	5.51	8.07	1009.19	200	600	15.56
4"	3.82	2.56	1.54	1.08	6.54	10.63	5.51	5.12	6.30	10.24	1606.84	200	600	24.54



Classification No. 1140 – 175 psig rated working pressure

Up to 2"

* UL certified to NSF/ANSI 61-8