

# GLOBE

## CLASS 150 BRONZE

Screw-In-Bonnet • Inside Screw • Rising Stem  
Integral Seat • Solid Wedge Disc

### CODE # 02 (AKC) THREADED

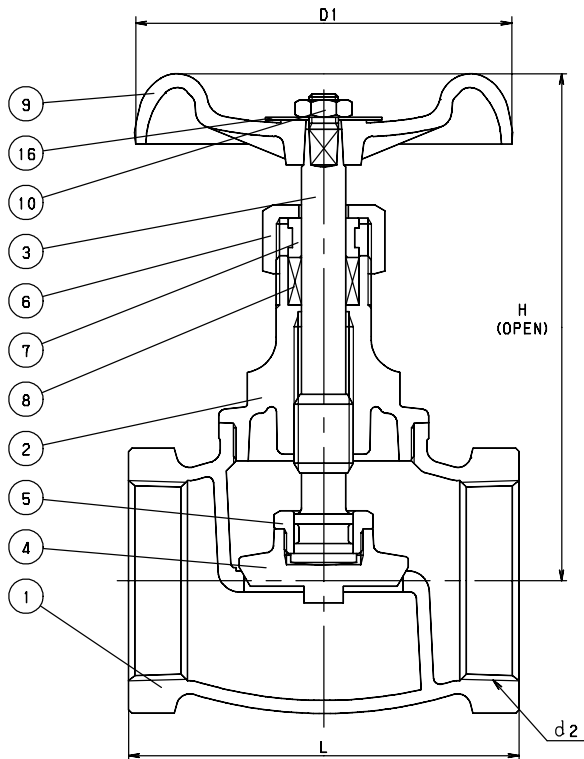

#### STANDARDS

END TO END	KITZ
THREADED ENDS	ANSI B1.20.1
DESIGN	KITZ

#### PRESSURE/TEMPERATURE

150 PSI - SATURATED STEAM TO 366°F - FLUID TO 406°F 300 PSI NON-SHOCK COLD WATER, OIL OR GAS
--

#### MATERIAL LIST

NO.	NAME OF PART	SPECIFICATION
1	BODY	CAST BRONZE (B584, C84400)
2	BONNET (1/4 - 2 1/2) (3)	FORGED BRASS (B283, C37700) CAST BRONZE (B584, C84400)
3	STEM	BRASS (KITZ "K" METAL)
4	DISC	CAST BRONZE (B584, C84400)
5	LOCK NUT	FORGED BRASS (B124, C37700)
6	PACKING NUT	FORGED BRASS (B283, C37700)
7	GLAND	BRASS ROD (B16)
8	GLAND PACKING	ARAMID FIBERS W/ GRAPHITE
9	HAND WHEEL (1/4 - 3/4) (1 - 3)	ZINC DIE-CAST (B86) ALUMINUM DIE-CAST (B85)
10	WHEEL NUT	CARBON STEEL
16	NAME PLATE	ALUMINUM

#### DIMENSIONS - WEIGHTS - QUANTITIES

d2 SIZE	H	D1	L	APPROX. NET WT.	CARTON QTY
1/4	2.60	1.97	1.73	35	80
3/8	2.68	1.97	1.73	43	80
1/2	3.11	2.36	2.09	43	60
3/4	3.66	2.76	2.56	65	56
1	4.09	3.15	3.03	60	36
1 1/4	5.00	3.54	3.35	65	25
1 1/2	5.71	3.94	3.94	66	16
2	6.85	4.53	4.69	51	8
2 1/2	7.83	5.31	5.47	55	6
3	8.46	6.10	6.22	55	4