

GLOBE

CLASS 125 BRONZE

Screw-In-Bonnet • Inside Screw • Rising Stem
Integral Seat • Solid Wedge Disc



CODE # 11 (AK125C)
THREADED

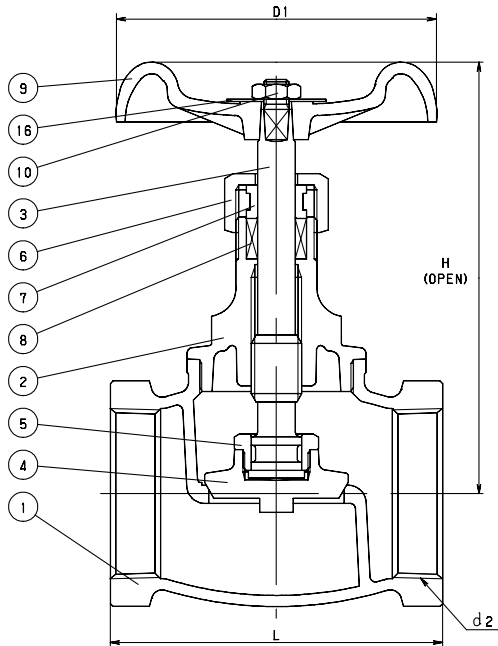

CODE # 12 (C125C)
SOLDER

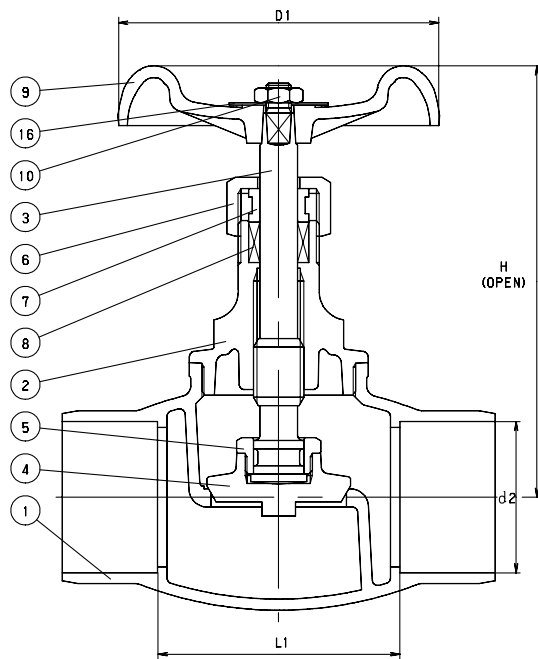

STANDARDS

END TO END	KITZ
THREADED ENDS	ANSI B1.20.1
DESIGN	MSS SP-80, TYPE 1
MILITARY	MSS SP-80, TYPE 1

PRESSURE/TEMPERATURE

125 PSI - SATURATED STEAM TO 353°F
- FLUID TO 406°F
200 PSI NON-SHOCK COLD WATER, OIL OR GAS

MATERIAL LIST

NO.	NAME OF PART	SPECIFICATION
1	BODY	CAST BRONZE (B62)
2	BONNET (1/2 - 2) (2 1/2, 3)	FORGED BRASS (B283 C37700) CAST BRONZE (B62)
3	STEM	BRASS (B62)
4	DISC	CAST BRONZE (B62)
5	LOCK NUT	FORGED BRASS (B124, C37700)
6	PACKING NUT	FORGED BRASS (B283, C37700)
7	GLAND	BRASS ROD (B16)
8	GLAND PACKING	ARAMID FIBERS W/ GRAPHITE
9	HAND WHEEL (1/4 - 3/4) (1 - 3)	ZINC DIE-CAST (B86) ALUMINUM DIE-CAST (B85)
10	WHEEL NUT	BRASS ROD (B16)
16	NAME PLATE	ALUMINUM

DIMENSIONS - WEIGHTS - QUANTITIES

SIZE d2	H	D1	L	L1	APPROX. NET WT.	CARTON QTY
1/2	2.99	2.36	2.09	1.52	0.71	48
3/4	3.86	2.76	2.56	1.80	1.37	36
1	4.25	3.15	3.03	2.12	1.80	36
1 1/4	5.39	3.54	3.35	2.60	2.63	16
1 1/2	6.30	3.94	3.94	2.94	3.88	12
2	7.09	4.53	4.69	3.43	6.63	8
2 1/2	7.95	5.31	5.91	4.61	10.51	4
3	9.69	6.10	7.01	5.81	15.54	3