

CHECK CLASS 125 BRONZE

Screw Cap • Integral Seat • PTFE Disc
Y-Pattern Swing Type

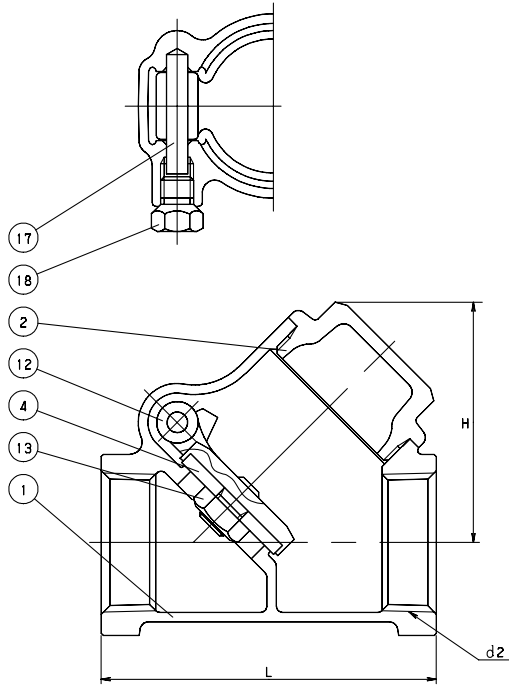

**CODE # 22T (AKYRT)
THREADED**



STANDARDS	
END TO END	KITZ
THREADED ENDS	ANSI B1.20.1
SOLDER JOINT ENDS	ANSI B16.18
DESIGN	MSS SP-80, TYPE 4
MILITARY	MSS SP-80, TYPE 4

PRESSURE/TEMPERATURE
125 PSI - SATURATED STEAM TO 353°F - FLUID TO 406°
200 PSI NON-SHOCK COLD WATER, OIL OR GAS

**SEE PRESSURE/TEMPERATURE LIMITATIONS FOR SOLDER JOINT VALVES - PAGE BIV-50.*

MATERIAL LIST		
NO.	NAME OF PART	SPECIFICATION
1	BODY	CAST BRONZE (ASTM B62)
2	CAP	FORGED BRASS (B283, C37700)
4	DISC	PTFE
12	DISC HOLDER	CAST BRONZE (B62)
13	DISC NUT (1/2 ~ 1) (1 1/4 ~ 2)	BRASS ROD (B16) FORGED BRASS (B283, C37700)
17	HINGE PIN	COPPER
18	PLUG	BRASS ROD (B16)

**CODE # 23T (CYRT)
SOLDER***

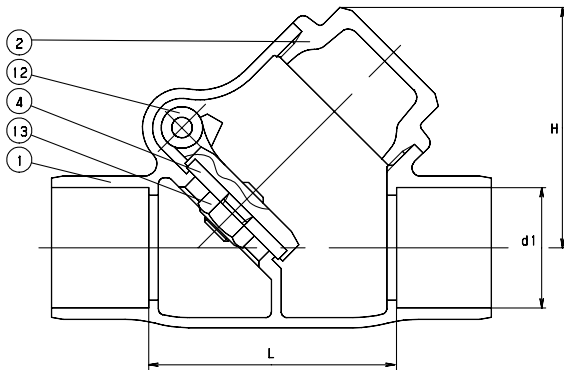

DIMENSIONS - WEIGHTS - QUANTITIES							
d2 SIZE	H	L	L1	d1		APPROX. NET WT.	CARTON QTY
				Max.	Min.		
1/2	1.57	2.20	1.64	.631	.627	0.53	96
3/4	1.93	2.76	1.88	.881	.877	0.89	60
1	2.28	3.15	2.31	1.132	1.128	1.30	48
1 1/4	2.80	3.74	2.83	1.382	1.378	1.87	24
1 1/2	3.15	4.33	3.21	1.633	1.628	2.70	18
2	3.74	5.04	4.02	2.133	2.128	4.14	12