

CHECK CLASS 125 BRONZE

Screw Cap • Integral Seat
Y-Pattern Swing Type Disc

BRONZE CHECK

CODE # 22 (AKYR) THREADED

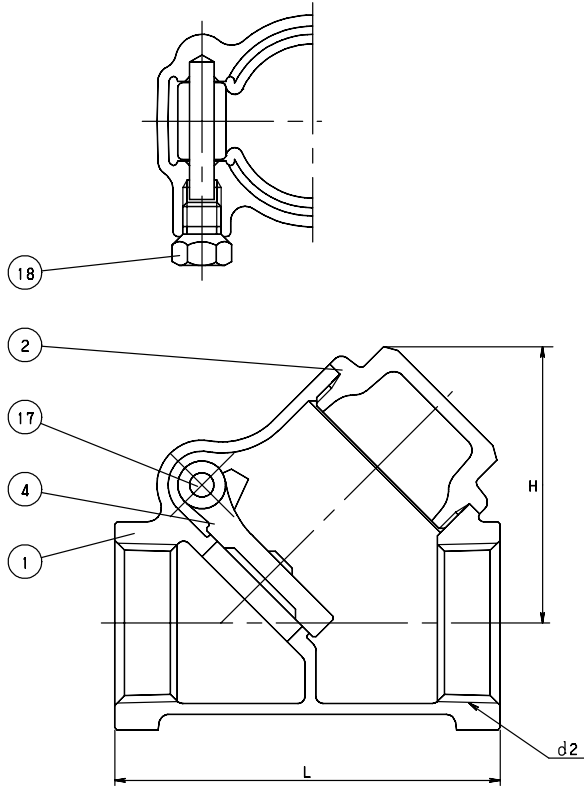

CODE # 23 (CYR) SOLDER*

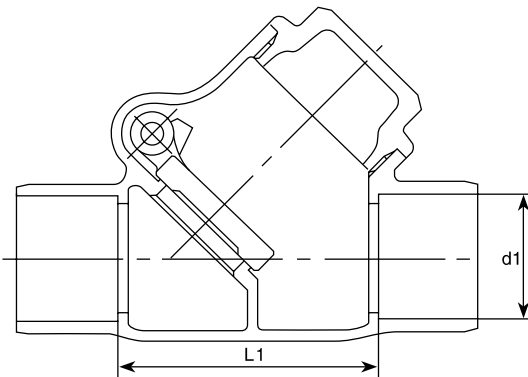

STANDARDS

END TO END	KITZ
THREADED ENDS	ANSI B1.20.1
SOLDER JOINT ENDS	ANSI B16.18
DESIGN	MSS SP-80, TYPE 3
MILITARY	MSS SP-80, TYPE 3

PRESSURE/TEMPERATURE

125 PSI - SATURATED STEAM TO 353°F
- FLUID TO 406°F
200 PSI NON-SHOCK COLD WATER, OIL OR GAS

*SEE PRESSURE/TEMPERATURE LIMITATIONS FOR SOLDER JOINT VALVES - PAGE BIV-50.

MATERIAL LIST

NO.	NAME OF PART	SPECIFICATION
1	BODY	CAST BRONZE (ASTM B62)
2	CAP	FORGED BRASS (B283, C37700)
4	DISC	CAST BRONZE (ASTM B62)
17	HINGE PIN	COPPER
18	PLUG	BRASS ROD (B16)

DIMENSIONS - WEIGHTS - QUANTITIES

d2 SIZE	H	L	L1	d1		APPROX. NET WT.	CARTON QTY
				Max.	Min.		
1/2	1.57	2.20	1.64	.631	.627	0.52	96
3/4	1.93	2.76	1.88	.881	.877	0.88	60
1	2.28	3.15	2.31	1.132	1.128	1.33	48
1 1/4	2.80	3.74	2.83	1.382	1.378	2.04	24
1 1/2	3.15	4.33	3.21	1.633	1.628	2.78	18
2	3.74	5.04	4.02	2.133	2.128	4.58	12
2 1/2	4.49	6.14	4.69	2.633	2.628	7.67	6
3	5.16	7.24	5.42	3.133	3.128	11.00	4