

GATE CLASS 125 BRONZE

Screw-In-Bonnet • Non-Rising Stem
Solid Wedge Disc

CODE # 27 (AKH) THREADED

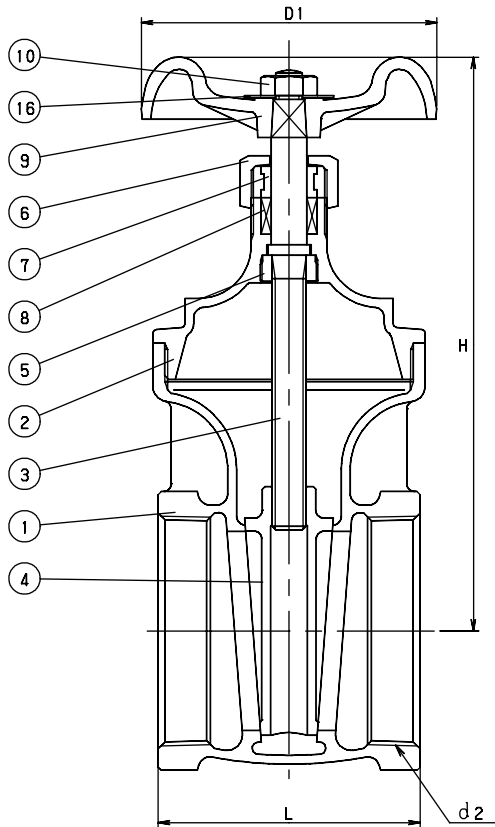

STANDARDS	
END TO END	KITZ
THREADED ENDS	ANSI B1.20.1
SOLDER JOINT ENDS	ANSI B16.18
WALL THICKNESS	KITZ
DESIGN	KITZ

PRESSURE/TEMPERATURE
125 PSI - SATURATED STEAM TO 353°F - FLUID TO 406°F
200 PSI NON-SHOCK COLD WATER, OIL OR GAS

**SEE PRESSURE/TEMPERATURE LIMITATIONS FOR SOLDER JOINT VALVES - PAGE BIV-50.*

MATERIAL LIST		
NO.	NAME OF PART	SPECIFICATION
1	BODY	CAST BRONZE (ASTM B62)
2	BONNET	CAST BRONZE (ASTM B62)
3	STEM	BRASS (KITZ "K" METAL)
4	DISC	CAST BRONZE (ASTM B62)
5	LOCK NUT	BRASS ROD (B16)
6	PACKING NUT	FORGED BRASS (B283, C37700)
7	GLAND	BRASS ROD (B16)
8	GLAND PACKING	ARAMID FIBERS W/ GRAPHITE
9	HAND WHEEL	ALUMINUM DIE-CAST (B85)
10	WHEEL NUT	CARBON STEEL
16	NAME PLATE	ALUMINUM



CODE # 28 (CH) SOLDER*

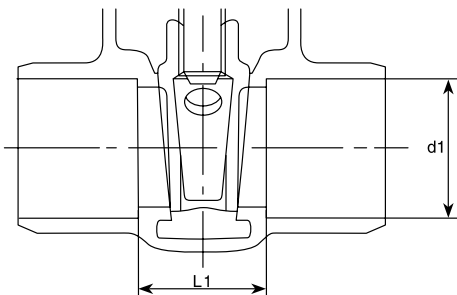

DIMENSIONS - WEIGHTS - QUANTITIES								
d2 SIZE	H	D1	L	L1	d1		APPROX. NET WT.	CARTON QTY
					Max.	Min.		
2 1/2	7.95	4.53	3.54	1.59	2.633	2.628	7.50	8
3	8.78	5.31	3.94	1.78	3.133	3.128	10.30	6
4	11.02	6.10	4.76	2.49	4.133	4.128	21.33	3