

CHECK CLASS 150 BRONZE

Y-Pattern Swing Check • Integral Seat
Swing Type Disc

CODE # 29 (AK150YR) THREADED

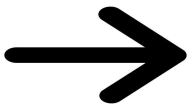
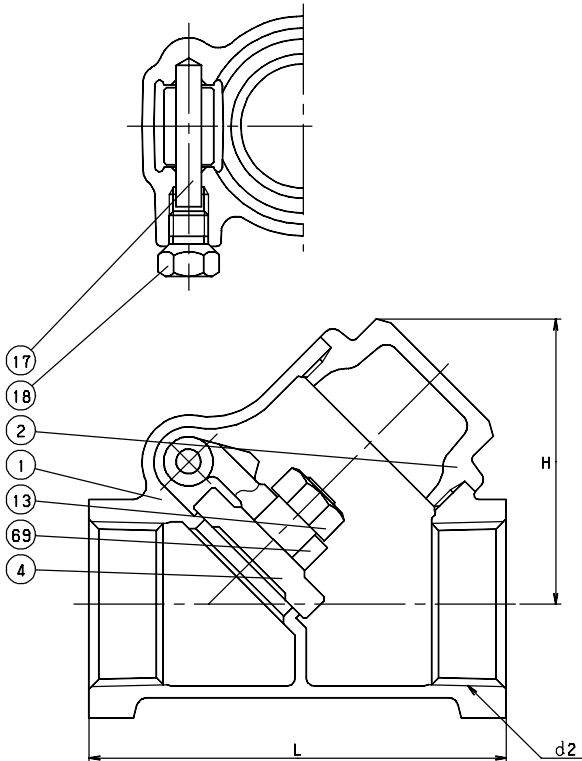

CODE # 30 (C150YR) SOLDER*

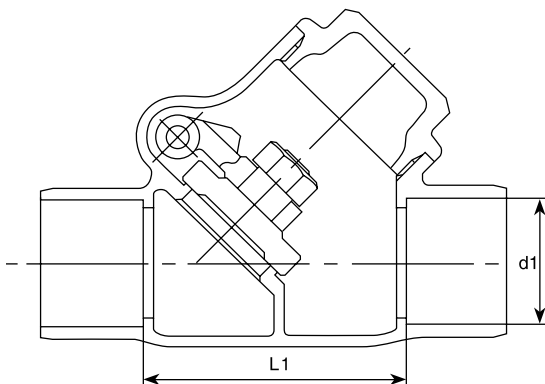

STANDARDS

END TO END	KITZ
THREADED ENDS	ANSI B1.20.1
SOLDER JOINT ENDS	ANSI B16.18
DESIGN	MSS SP-80, TYPE 3
MILITARY	MSS SP-80, TYPE 3

PRESSURE/TEMPERATURE

150 PSI - SATURATED STEAM TO 366°F
- FLUID TO 406°F
300 PSI NON-SHOCK COLD WATER, OIL OR GAS

**SEE PRESSURE/TEMPERATURE LIMITATIONS FOR SOLDER JOINT VALVES - PAGE BIV-50.*

MATERIAL LIST

NO.	NAME OF PART	SPECIFICATION
1	BODY	CAST BRONZE (ASTM B62)
2	CAP	FORGED BRASS (B283, C37700)
4	DISC	CAST BRONZE (ASTM B62)
13	DISC NUT	BRASS ROD (B16)
17	HINGE PIN	COPPER
18	PLUG	BRASS ROD (B16)
69	ARM	CAST BRONZE (ASTM B62)

DIMENSIONS - WEIGHTS - QUANTITIES

d2 SIZE	H	L	L1	d1		APPROX. NET WT.	CARTON QTY
				Max.	Min.		
3/8	1.54	2.13	1.64	.506	.502	0.44	96
1/2	1.54	2.36	1.64	.631	.627	0.54	80
3/4	1.93	2.83	1.89	.881	.877	1.00	48
1	2.28	3.31	2.31	1.132	1.128	1.25	36
1 1/4	2.76	3.90	2.82	1.382	1.378	2.00	24
1 1/2	3.11	4.45	3.21	1.633	1.628	2.81	16
2	3.74	5.16	4.01	2.133	2.128	5.13	8
2 1/2	4.49	6.38	4.70	2.633	2.628	12.50	4
3	5.20	7.32	5.42	3.133	3.128	16.00	3