

CHECK

250 WOG BRONZE

Silent Type • Spring Loaded Vertical Lift Check
Renewable FPM disc

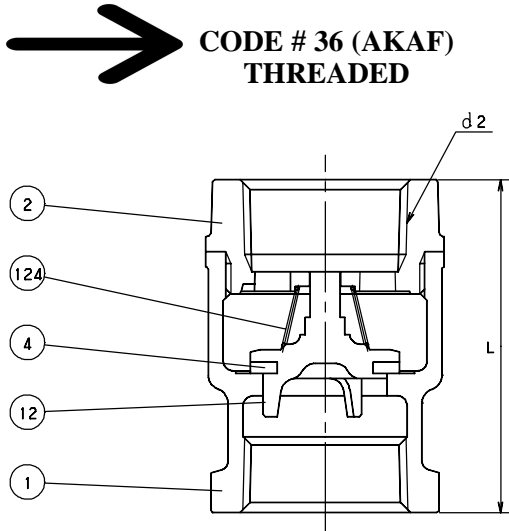

**CODE # 26 (CAF)
SOLDER***

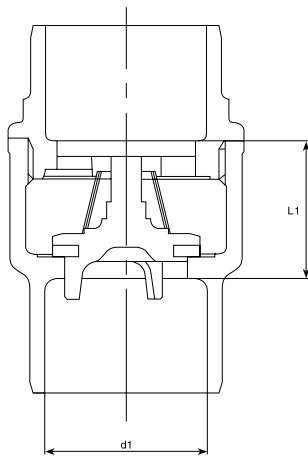

STANDARDS

END TO END	KITZ
THREADED ENDS	ANSI B1.20.1
SOLDER JOINT ENDS	ANSI B16.18
DESIGN	KITZ

PRESSURE/TEMPERATURE

175 PSI @ 176°F - MAX. PRESSURE/TEMP. RATING
250 PSI NON-SHOCK COLD WATER, OIL OR GAS

*SEE PRESSURE/TEMPERATURE LIMITATIONS FOR SOLDER JOINT
VALVES - PAGE BIV-50.

MATERIAL LIST

NO.	NAME OF PART	SPECIFICATION
1	BODY	CAST BRONZE (B584, C84400)
2	CAP	CAST BRONZE (B584, C84400)
4	DISC	FPM
12	DISC HOLDER	CAST BRONZE (B584, C84400)
124	SPRING	PHOSPHOR BRONZE

DIMENSIONS - WEIGHTS - QUANTITIES

d2 SIZE	L	L1	d1		APPROX. NET WT.	CARTON QTY
			Max.	Min.		
1/2	2.09	1.40	.631	.627	0.38	160
3/4	2.32	1.50	.881	.877	0.56	96
1	2.64	1.68	1.132	1.128	0.86	72
1 1/4	3.07	1.88	1.382	1.378	1.25	48
1 1/2	3.31	2.15	1.633	1.628	1.78	36
2	3.86	2.52	2.133	2.128	2.88	24

Note: Cracking pressure all sizes 2.85 PSI.