

# ANGLE GLOBE

## CLASS 150 BRONZE

Screw-In-Bonnet • Inside Screw • Rising Stem  
Bronze Disc

BRONZE ANGLE GLOBE

**CODE # 38 (AKCA)  
THREADED**

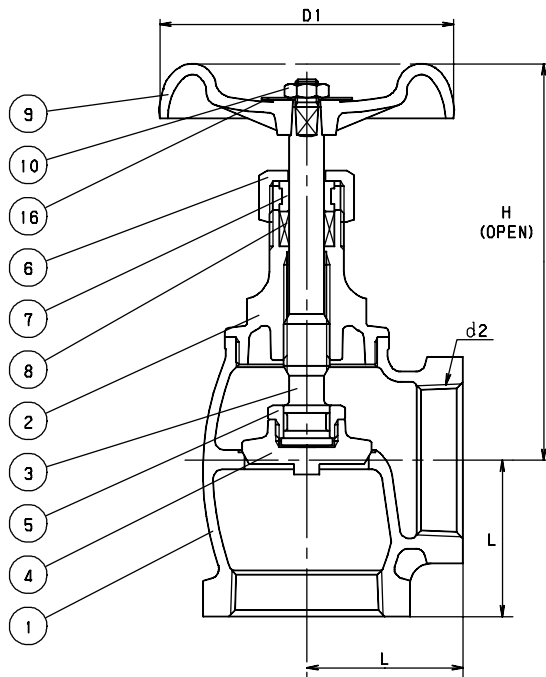

### STANDARDS

END TO END	KITZ
THREADED ENDS	ANSI B1.20.1
DESIGN	KITZ

### PRESSURE/TEMPERATURE

150 PSI - SATURATED STEAM TO 366°F - FLUID TO 406°F
300 PSI NON-SHOCK COLD WATER, OIL OR GAS

### MATERIAL LIST

NO.	NAME OF PART	SPECIFICATION
1	BODY	CAST BRONZE (B584, C84400)
2	BONNET (1/4 - 2 1/2) (3)	FORGED BRASS (B283, C37700) CAST BRONZE (B584, C84400)
3	STEM	BRASS (KITZ "K" METAL)
4	DISC	CAST BRONZE (B584, C84400)
5	LOCK NUT	FORGED BRASS (B124, C37700)
6	PACKING NUT	FORGED BRASS (B283, C37700)
7	GLAND	BRASS ROD (B16)
8	GLAND PACKING	ARAMID FIBERS W/ GRAPHITE
9	HAND WHEEL (1/4 - 3/4) (1 - 3)	ZINC DIE-CAST (B86) ALUMINUM DIE-CAST ( B85)
10	WHEEL NUT	CARBON STEEL
16	NAME PLATE	ALUMINUM

### DIMENSIONS - WEIGHTS - QUANTITIES

d2 SIZE	H	D1	L	APPROX. NET WT.	CARTON QTY
1/4	2.60	1.97	.83	0.44	80
3/8	2.68	1.97	.95	0.51	80
1/2	3.11	2.36	1.10	0.58	60
3/4	3.66	2.76	1.34	0.98	56
1	4.09	3.15	1.57	1.42	36
1 1/4	5.00	3.54	1.85	2.28	25
1 1/2	5.71	3.94	2.05	3.56	16
2	6.85	4.53	2.40	6.13	8
2 1/2	7.83	5.31	2.91	8.50	6
3	8.46	6.10	3.35	11.50	4

**NOTE: NOT INTENDED FOR USE IN A POTABLE WATER SYSTEM - COMPLIANT STATEMENT  
PROP 65, STATE OF CALIFORNIA**