

GATE CLASS 150 BRONZE

Screw-In-Bonnet • Rising Stem
Solid Wedge Disc

BRONZE GATE

CODE # 25 (AK150L) THREADED

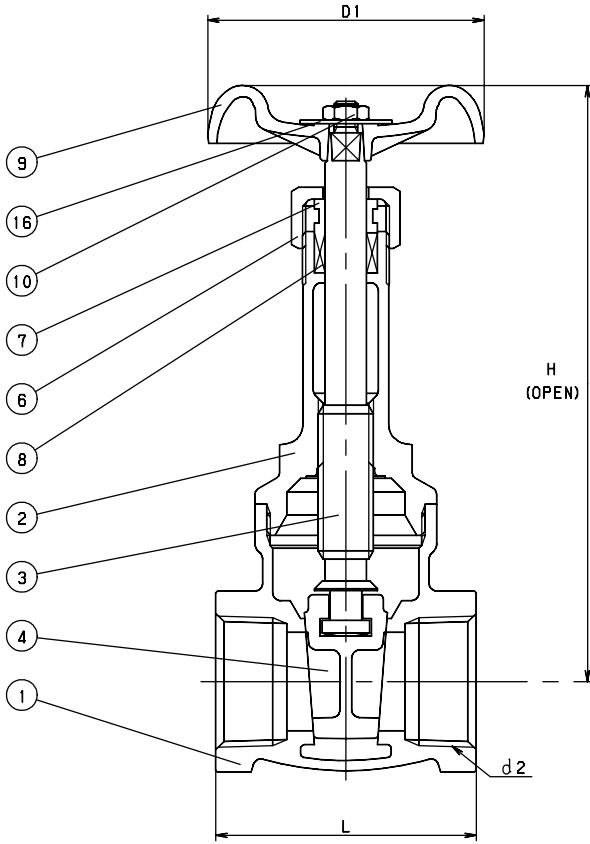

CODE # 45 (C150L) SOLDER*

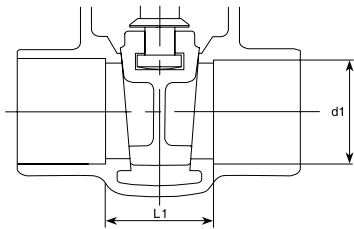

STANDARDS

END TO END	KITZ
THREADED ENDS	ANSI B1.20.1
SOLDER JOINT ENDS	ANSI B16.18
DESIGN	MSS SP-80, TYPE 2
MILITARY	MSS SP-80, TYPE 2

PRESSURE/TEMPERATURE

150 PSI - SATURATED STEAM TO 366°F
- FLUID TO 406°F
300 PSI NON-SHOCK COLD WATER, OIL OR GAS

**SEE PRESSURE/TEMPERATURE LIMITATIONS FOR SOLDER JOINT
VALVES - PAGE BIV-50.*

MATERIAL LIST

NO.	NAME OF PART	SPECIFICATION
1	BODY	CAST BRONZE (ASTM B62)
2	BONNET	CAST BRONZE (ASTM B62)
3	STEM	CAST BRONZE (ASTM B62)
4	DISC	CAST BRONZE (ASTM B62)
6	PACKING NUT	FORGED BRASS (B283, C37700)
7	GLAND	BRASS ROD (B16)
8	GLAND PACKING	ARAMID FIBERS W/ GRAPHITE
9	HAND WHEEL (1/2 - 1)	ZINC DIE-CAST (B86)
	(1 1/4 - 3)	ALUMINUM DIE-CAST (B85)
10	WHEEL NUT	BRASS ROD (B16)
16	NAME PLATE	ALUMINUM

DIMENSIONS - WEIGHTS - QUANTITIES

d2 SIZE	H	D1	L	L1	d1		APPROX. NET WT.	CARTON QTY
					Max.	Min.		
1/2	5.39	2.17	2.01	.93	.631	.627	1.00	48
3/4	6.18	2.76	2.20	1.02	.881	.877	1.50	36
1	7.09	2.76	2.60	1.17	1.132	1.128	1.72	24
1 1/4	8.50	3.15	2.68	1.29	1.382	1.378	3.88	16
1 1/2	10.12	3.54	2.91	1.21	1.633	1.628	4.33	12
2	11.65	3.94	3.31	1.61	2.133	2.128	6.38	8
2 1/2	15.16	6.10	4.72	-	-	-	14.75	4
3	17.01	6.10	5.51	-	-	-	20.33	3