

GATE CLASS 150 BRONZE

Screw-In Bonnet • Inside Screw • Non-Rising Stem
Solid Wedge Disc

BRONZE GATE

**→ CODE # 46 (AK150E)
THREADED**

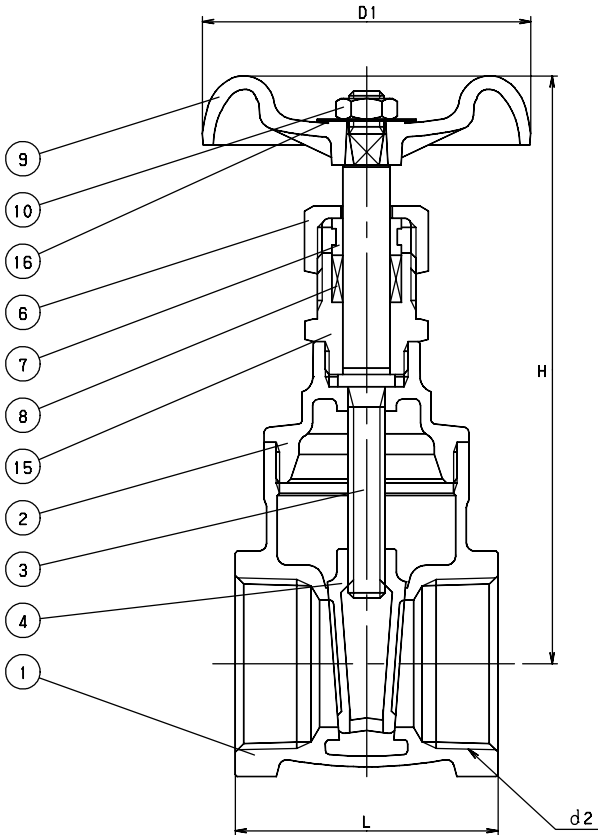

**CODE # 64 (C150E)
SOLDER***

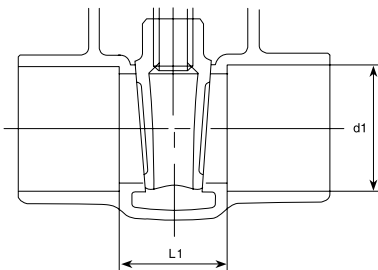

STANDARDS

END TO END	KITZ
THREADED ENDS	ANSI B1.20.1
SOLDER JOINT ENDS	ANSI B16.18
DESIGN	MSS SP-80, TYPE 1A
MILITARY	MSS SP-80, TYPE 1A

PRESSURE/TEMPERATURE

150 PSI - SATURATED STEAM TO 366°F
- FLUID TO 406°F
300 PSI NON-SHOCK COLD WATER, OIL OR GAS

**SEE PRESSURE/TEMPERATURE LIMITATIONS FOR SOLDER JOINT
VALVES - PAGE BIV-50.*

MATERIAL LIST

NO.	NAME OF PART	SPECIFICATION
1	BODY	CAST BRONZE (ASTM B62)
2	BONNET	CAST BRONZE (ASTM B62)
3	STEM	CAST BRONZE (ASTM B62)
4	DISC	CAST BRONZE (ASTM B62)
6	PACKING NUT	FORGED BRASS (B283, C37700)
7	GLAND	BRASS ROD (B16)
8	GLAND PACKING	ARAMID FIBERS W/ GRAPHITE
9	HAND WHEEL (3/8 - 1) (1 1/4 - 2)	ZINC DIE-CAST (B86) ALUMINUM DIE-CAST (B85)
10	WHEEL NUT	BRASS ROD
15	STUFFING BOX (3/8 - 1 1/2) (2)	BRASS ROD (B16) FORGED BRASS (B283, 37700)
16	NAME PLATE	ALUMINUM

DIMENSIONS - WEIGHTS - QUANTITIES

SIZE d2	H	D1	L	L1	d1		APPROX. NET WT.	CARTON QTY
					Max.	Min.		
3/8	3.39	1.97	1.69	-	-	-	0.68	96
1/2	3.86	2.17	1.93	.81	.631	.627	0.97	72
3/4	4.49	2.76	2.09	.86	.881	.877	1.24	54
1	4.96	2.76	2.40	.98	1.132	1.128	1.72	36
1 1/4	5.70	3.15	2.68	1.17	1.382	1.378	2.75	24
1 1/2	6.92	3.54	2.91	1.28	1.633	1.628	4.06	16
2	7.91	3.94	3.31	1.57	2.133	2.128	6.38	8