

# BUTTERFLY VALVES - 250 PSI\*

Lug & Wafer Design • Ductile Iron Body • Extended Neck  
Bi-Directional • Molded Seat • ISO Mounting Pad • Locking Lever  
**SIZE 2" - 8"**

DESIGN STANDARDS: MSS SP-67 & API-609 Cat. A END CONNECTION: ANSI CL. 125/150 FLANGES WALL THICKNESS: KITZ STD

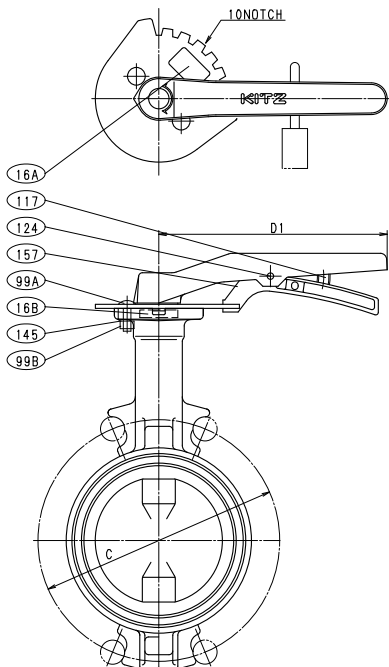
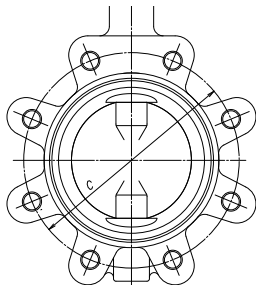
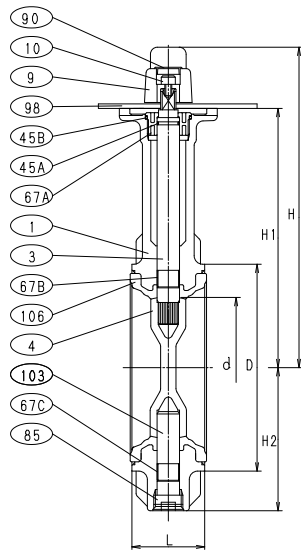

MATERIAL LIST		
NO.	NAME OF PART	SPECIFICATION
1	BODY	DUCTILE IRON (A536 Gr. 65-45-12)
3	STEM* (1)	STAINLESS STEEL (A276, Type 410 or 316)
4	DISC	ALUMINUM BRONZE
9	HANDLE	ALUMINUM DIE-CAST
10	HANDLE BOLT	CARBON STEEL
16A/B	NAME PLATE	ALUMINUM
45A	O-RING	EPDM
45B	O-RING	EPDM
67A	BEARING	POLYACETAL
67B/C	STEM BEARING	G/F PTFE
85	PLUG	ZINC DIE-CAST (2)
90	CAP	P.V.C.
98	INDEX PLATE	CARBON STEEL
99A	SET BOLT	CARBON STEEL
99B	NUT	CARBON STEEL
103	BOTTOM STEM*	STAINLESS STEEL (A276, TYPE 410 or 316)
106	SEAT RUBBER (3)	EPDM
145	SPRING WASHER	CARBON STEEL

- (1) Line scribed on top of the stem indicates the disc direction.
- (2) Chromate Coating
- (3) Vulcanized to the Body

DIMENSIONS										
SIZE	d	D	C	H	H1	H2	L	D1	Lbs.	Wafer Lug Lbs. Kgs.
in. 2	1.97	3.54	4.75	7.52	5.79	2.64	1.69	7.09	4.2	6.6
mm 50	50	90	120.5	191	147	67	43	180	1.9	3.0
in. 2½	2.56	4.09	5.50	7.83	6.10	2.95	1.81	7.09	5.1	7.9
mm 65	65	104	139.5	199	155	75	46	180	2.3	3.6
in. 3	3.15	4.88	6.00	8.54	6.81	3.58	1.81	7.09	6.8	11.0
mm 80	80	124	152.5	217	173	91	46	180	3.1	5.1
in. 4	3.94	5.75	7.50	8.94	7.20	3.98	2.06	7.09	7.7	18.0
mm 100	100	146	190.5	227	183	101	52	180	3.5	8.1
in. 5	4.92	6.93	8.50	10.43	8.31	5.00	2.19	9.06	13.0	25.0
mm 125	125	176	216	265	211	127	56	230	5.8	11.0
in. 6	5.91	8.11	9.50	10.91	8.78	5.47	2.19	9.06	18.0	30.0
mm 150	150	206	241.5	277	223	139	56	230	8.0	14.0
in. 8	7.76	10.12	11.75	11.61	9.76	6.65	2.38	13.78	28.0	48.0
mm 200	197	257	298.5	295	248	169	60	350	13.0	22.0

**NOTE:**  
KITZ lug style butterfly valves are rated for bi-directional dead end service to full working pressure of the valve with the downstream flange removed. In dead end service exceeding 96 hours, a downstream flange is recommended.



DJ SERIES BUTTERFLY VALVES - 200 PSI\* - LEVER OPERATOR