

FORGED BRASS BALL VALVE

MAINTENANCE FREE DOUBLE O-RING STEM SEALS

Two Piece Body • Full Port • Chrome Plated / Vented Ball
 Blowout Proof Stem (Ni Plated) • PTFE Seats
 CSA (US/C) • UL • FM • NSF

CODE # 58 (AKSZA) THREADED

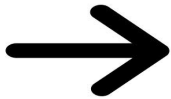
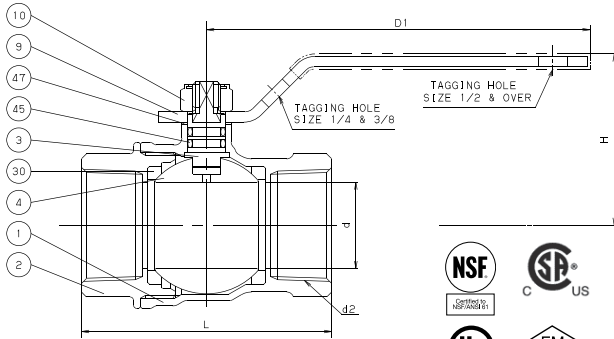

CODE # 59 (CSZA) SOLDER*

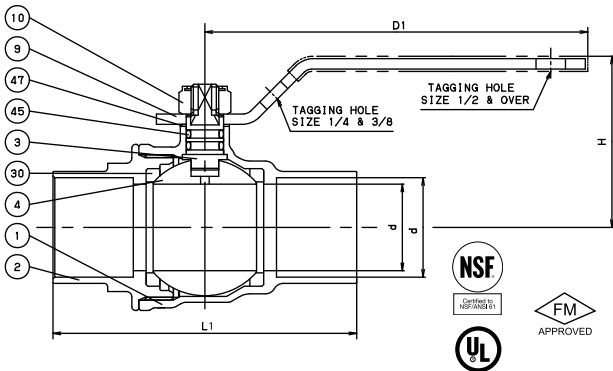

*REFERENCE VALVE INSTALLATION TIPS FOR SOUND SOLDER JOINTS (PAGE BV-70) OR SEE INSTALLATION SHEET PACKAGED WITH VALVE.

SPECIFICATION

Approved valve shall have two piece forged brass body, blowout proof stem (Ni Plated), PTFE seats, maintenance free double o-ring stem seals, chrome plated ball and full port design. Valves shall be pressure rated to 150 WSP/600 WOG and conform to MSS-SP 110 and certified to CSA, UL & FM.

KITZ Code No. 58 (AKSZA) Threaded Ends
 59 (CSZA) Solder Ends

STANDARDS

END TO END	KITZ
THREADED ENDS	ANSI B1.20.1
SOLDER JOINT ENDS	ANSI B16.18
WALL THICKNESS	KITZ
CONFORMS TO MSS-SP 110 - REPLACES US. FED. SPEC. WWW-V-35B, TYPE II, CLASS A, STYLE 3	

PRESSURE/TEMPERATURE

150 PSI SATURATED STEAM TO 366°F
600 PSI - NON-SHOCK COLD WATER, OIL OR GAS

NOTE: PRESSURE/TEMPERATURE CHART - PAGE BV-35

MATERIAL LIST

NO.	NAME OF PART	SPECIFICATION
1	BODY	FORGED BRASS (B283, C37700)
2	BODY CAP	FORGED BRASS (B283, C37700)
3	STEM	(1) BRASS ROD (B16)
4	BALL (Vented)	(2) FORGED BRASS (B283, C37700) STRAIGHT OR HOLLOW BALL
9	HANDLE	(3) CARBON STEEL
10	HANDLE NUT	CARBON STEEL
30	BALL SEATS	PTFE
45	O-RINGS	FPM
47	THRUST WASHER	PBT

NOTES: (1) Ni PLATING
 (2) CR. PLATING
 (3) ELECTROPLATED ZINC WITH PLASTIC COVERING

DIMENSIONS • WEIGHTS • QUANTITIES

	d2 SIZE	d	H	D1	L	L1	d1		APPROX. NET WT.	CARTON QTY
							Max.	Min.		
in.	1/4	0.39	1.46	2.76	1.65	1.05	.381	.377	29	120
mm.		9.9	37.1	70.1	41.9	26.7	9.7	9.6	13.2	
in.	3/8	0.39	1.46	2.76	1.65	1.11	.506	.502	29	120
mm.		9.9	37.1	70.1	41.9	28.2	12.9	12.8	13.2	
in.	1/2	0.59	1.57	3.15	2.08	1.13	.631	.627	29	96
mm.		14.0	39.9	80.0	52.8	28.7	16.0	15.9	13.2	
in.	3/4	0.79	1.69	3.15	2.36	1.37	.881	.877	45	60
mm.		20.1	42.9	80.0	59.9	34.8	22.4	22.3	20.5	
in.	1	0.98	1.97	4.33	2.83	1.64	1.132	1.128	60	36
mm.		24.9	50.0	50.038	71.9	41.7	28.8	28.7	27.3	
in.	1 1/4	1.26	2.16	4.33	3.31	2	1.382	1.378	68	24
mm.		32.0	54.9	54.864	84.1	50.8	35.1	35.0	30.9	
in.	1 1/2	1.57	2.52	5.9	3.62	2.35	1.633	1.628	50	16
mm.		39.9	64.0	149.9	91.9	59.7	41.5	41.4	22.7	
in.	2	1.97	2.83	5.9	4.33	2.83	2.133	2.128	71	16
mm.		50.0	71.9	149.9	149.86	71.9	54.2	54.1	32.3	

CERTIFICATIONS:

NSF/ANSI STANDARDS 61-8, C-HOT (180°F/82°C)
 CSA (US/C) -40°C~65°C (-40°F~149°F)
 CGA 9.1b-2001/ANSI 21.15b-2006 - .5 PSI
 CGA CR 91-002 - 2 PSI
 ASME B16.44 - 5 PSI
 CAN/CGA 3.16-M88 - 125 PSI
 ASME B16.33-2002 - 125 PSI
 UL-258 - 175 WWP (Fire Trim Protection Valves)
 FM-1140 - 175 WWP (Fire Protection Systems)