

# BUTTERFLY VALVES - 150 PSI

Lug & Wafer Design • Ductile Iron Body • Extended Neck  
 Bi-Directional • Bonded Seat • ISO Mounting Pad • Gear Operator  
**SIZE 14" - 24"**

DESIGN STANDARDS: MSS SP-67 & API-609 Cat. A END CONNECTION: ANSI CL. 125/150 FLANGES WALL THICKNESS: KITZ STD

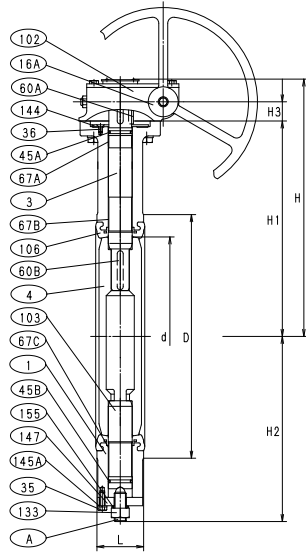

MATERIAL LIST		
NO.	NAME OF PART	SPECIFICATION
1	BODY	DUCTILE IRON (A536 Gr. 65-45-12)
3	STEM (1)	STAINLESS STEEL (A276, Type 410, 420 or 316)
4	DISC	DUCTILE IRON, AL. BRONZE, AND 316 SS
16A/B	NAME PLATE	ALUMINUM
35	END PLATE BOLTS	CARBON STEEL
36	GLAND PLATE BOLT	STAINLESS STEEL
45A/B	O-RING	NBR/EPDM
60A/B	KEY	CARBON STEEL
67A/B/C	STEM BEARING	G/F PTFE
99	SET BOLTS	CARBON STEEL
102	GEAR UNIT	
103	BOTTOM STEM (14")	STAINLESS STEEL (A276, Type 410 or 316)
	BOTTOM STEM (16"-24")	STAINLESS STEEL (A276, Type 420 or 316)
106	SEAT RUBBER	NBR/EPDM
133	NUT	CARBON STEEL
144	GLAND PLATE	CARBON STEEL
145A/B	SPRING WASHER	CARBON STEEL
147	END PLATE	CARBON STEEL
155	SEAL WASHER	CARBON STEEL
A	SUPPORT BOLT	ALLOY STEEL



**Code # 5121-E-G**  
 Body Style: Wafer Design  
 Disc: Aluminum Bronze  
 Liner: EDPM  
 Operator: Gear Operator

(1) Type 410 is standard in 14" with D.I. and Al.Bz. disc.

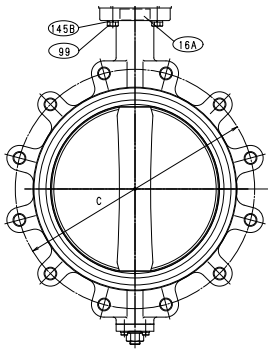

DIMENSIONS												
SIZE	d	D	C	H	H1	H2	H3	L	D1	L1	Wafer Lug	
											Lbs.	Lbs.
											Kgs.	Kgs.
in. 14	13.15	16.02	18.75	17.60	14.17	12.17	1.85	3.06	12.20	8.66	119	160
mm 350	334	407	476.5	447	360	309	47	77.7	310	220	54	72
in. 16	15.16	18.35	21.25	19.76	16.34	13.43	1.85	4.00	12.20	8.66	172	247
mm 400	385	466	539.5	502	415	341	47	101.6	310	220	78	112
in. 18	17.09	20.55	22.75	20.71	17.28	14.37	1.85	4.50	12.20	8.66	252	337
mm 450	434	522	578	526	439	365	47	114.3	310	220	114	153
in. 20	18.98	22.64	25.00	23.11	19.21	16.30	2.36	5.00	19.69	14.17	309	430
mm 500	482	575	635	587	488	414	60	127	500	360	140	195
in. 24	22.80	26.77	29.50	25.00	21.10	18.23	2.36	6.06	19.69	14.17	529	712
mm 600	579	680	749.5	635	536	463	60	153.9	500	360	240	323

For gear operator details, refer to page 20.



**Code # 6121-E-G**  
 Body Style: Wafer Design  
 Disc: Aluminum Bronze  
 Liner: EDPM  
 Operator: Gear Operator

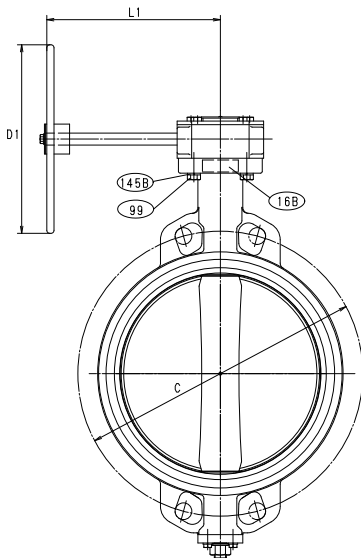

**NOTE:**

KITZ lug style butterfly valves are rated for bi-directional dead end service to full working pressure of the valve with the downstream flange removed. In dead end service exceeding 96 hours, a downstream flange is recommended.

DJ SERIES BUTTERFLY VALVES - 150 PSI - GEAR OPERATOR