

# STRAINER

## CLASS 125 IRON

Y-Pattern • Bolted Cover • Blow-Out-Plug  
Stainless Steel (304) Screen

### CODE # 80 (125FCYU)

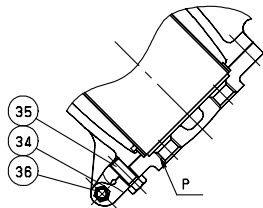
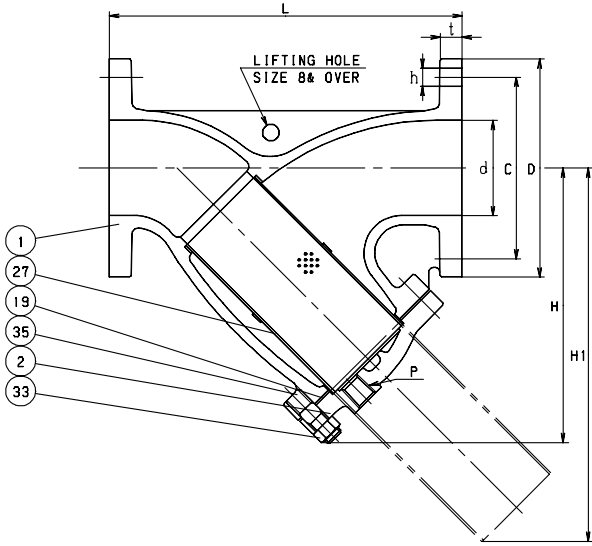

8 & Larger

STANDARDS	
END TO END	KITZ
THREADED ENDS	ANSI B16.1, CLASS 125
WALL THICKNESS	KITZ
DESIGN	KITZ

PRESSURE/TEMPERATURE	
125 PSI - SATURATED STEAM TO 353°F	
- FLUID TO 406°F	
200 PSI NON-SHOCK COLD WATER, OIL OR GAS	

MATERIAL LIST		
NO.	NAME OF PART	SPECIFICATION
1	BODY	CAST IRON (A126 CLASS B)
2	COVER	CAST IRON (A126 CLASS B)
19	GASKET	NON-ASBESTOS SHEET
27	SCREEN	STAINLESS STEEL (A167, TYPE 304)
33	COVER NUT (2 - 6) (1S)	CARBON STEEL (A307 GR. B)
34	COVER HINGE NUT	STAINLESS STEEL (A194 GR. B8)
35	COVER BOLT (2 - 6) (1S)	CARBON STEEL (A307 GR. B)
	(8 - 12)	STAINLESS STEEL (A193 GR. B8)
36	COVER HINGE BOLT	STAINLESS STEEL (A193 GR. B8)

1S = 1 Set

DIMENSIONS - WEIGHTS - QUANTITIES												
d2 SIZE	d	L	H	H1	D	P	BOLT HOLE		BOLT	t	APPROX. NET WT.	
							C	No.	h	SIZE		
2	1.97	9.84	6.61	8.58	6.00	1/2	4.75	4	.75	5/8	.62	30
2 1/2	2.56	11.22	8.35	11.22	7.00	1/2	5.50	4	.75	5/8	.68	50
3	3.15	12.40	9.53	13.39	7.50	1/2	6.00	4	.75	5/8	.75	77
4	3.94	14.57	11.18	15.39	9.00	1/2	7.50	8	.75	5/8	.94	76
5	4.92	16.54	12.80	17.72	10.00	1/2	8.50	8	.87	3/4	.94	126
6	5.91	19.29	14.57	19.76	11.00	3/4	9.50	8	.87	3/4	1.00	171
8	7.87	22.44	17.32	23.35	13.50	3/4	11.75	8	.87	3/4	1.12	242
10	9.84	26.77	20.28	27.48	16.00	1	14.25	12	.98	7/8	1.18	411
12	11.81	31.50	23.62	32.40	19.00	1	17.00	12	.98	7/8	1.25	561